

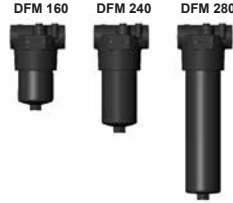

Pressure Filter DFM with Differential Pressure Relief Valve

up to 280 l/min, up to 400 bar



1. TECHNICAL SPECIFICATIONS

1.1 FILTER HOUSING

Construction

The filter housings are designed in accordance with international regulations. They consist of a filter head and a screw-in filter bowl.

Standard equipment:

- differential pressure controlled relief valve
- connection for a clogging indicator

1.2 FILTER ELEMENTS

HYDAC filter elements are validated and their quality is constantly monitored according to the following standards:

- ISO 2941
- ISO 2942
- ISO 2943
- ISO 3724
- ISO 3968
- ISO 11170
- ISO 16889

Contamination retention capacities in g

DFM	Betamicon® BH4HC			
	3 µm	5 µm	10 µm	20 µm
160	12.9	12.6	13.9	15.9
240	21.6	21.1	23.2	26.5
280	48.1	47.1	51.8	59.1

Filter elements are available with the following pressure stability values:
Betamicon® (BH4HC): 210 bar

1.3 FILTER SPECIFICATIONS

Nominal pressure	400 bar
Fatigue strength	At nominal pressure 10 ⁶ cycles from 0 to nominal pressure
Temperature range	-30 °C to +100 °C (-30 °C to -10 °C: p _{max} = 200 bar)
Material of filter head	EN-GJS-400-15
Material of filter bowl	Steel
Type of clogging indicator	VD (differential pressure measurement up to 420 bar operating pressure)
Pressure setting of the clogging indicator	5 bar (others on request)
Cracking pressure of differential pressure controlled relief valve	20 bar (others on request)
	NOTE: On request, BN4HC elements (pressure stability up to 20 bar) can also be used at lower cracking pressures.

1.4 SEALS

NBR (=Perbunan)

1.5 INSTALLATION

Inline filter

1.6 SPECIAL MODELS AND ACCESSORIES

With pressure release / oil drain plug (SO184)

1.7 SPARE PARTS

See Original Spare Parts List

1.8 CERTIFICATES AND APPROVALS

On request

1.9 COMPATIBILITY WITH HYDRAULIC FLUIDS ISO 2943

- Hydraulic oils H to HLPD DIN 51524
- Lubrication oils DIN 51517, API, ACEA, DIN 51515, ISO 6743
- Compressor oils DIN 51506
- Biodegradable operating fluids VDMA 24568 HETG, HEES, HEPG
- Fire-resistant fluids HFA, HFB, HFC and HFD
- Operating fluids with high water content (> 50 % water content) on request

1.10 MAINTENANCE INSTRUCTIONS

- Filter housings must be earthed.
- When using electrical clogging indicators, the electrical power supply to the system must be switched off before removing the clogging indicator connector.

Symbol for hydraulic systems

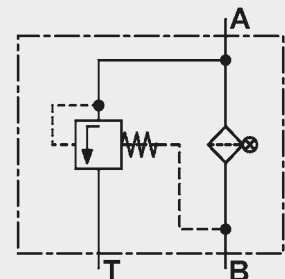

2. MODEL CODE (also order example)

DFM BH/HC 240 S E 10 D 1 . X /-L24

2.1 COMPLETE FILTER

Filter type _____

DFM

Filter material of element _____

BH/HC Betamicron® (BH4HC)

Size of filter or element _____

DFM: 160, 240, 280

Operating pressure _____

S = 400 bar

Type and size of connection _____

Type	Port	Filter size		
		160	240	280
E	G1 ¼	●	●	●

Filtration rating in µm _____

BH/HC : 3, 5, 10, 20

Type of clogging indicator _____

Y plastic blanking plug in indicator port

A stainless steel blanking plug in indicator port

B visual

C electrical

D visual and electrical

for other clogging indicators,
see brochure no. 7.050../..

Type code _____

1

Modification number _____

X the latest version is always supplied

Supplementary details _____

L... light with appropriate voltage (24, 48, 110, 220 Volt)

LED 2 light-emitting diodes up to 24 Volt

SO184 pressure release/oil drain screw

V FPM seals

only for clogging
indicators type "D"

2.2 REPLACEMENT ELEMENT

0240 D 010 BH4HC /-V

Size _____

0160, 0240, 0280

Type _____

D

Filtration rating in µm _____

BH4HC: 003, 005, 010, 020

Filter material _____

BH4HC

Supplementary details _____

V (for descriptions, see Point 2.1)

2.3 REPLACEMENT CLOGGING INDICATOR

VD 5 D . X /-L24

Type of indicator _____

VD differential pressure indicator up to 420 bar operating pressure

Pressure setting _____

5 standard 5 bar, others on request

Type of clogging indicator _____

D (see Point 2.1)

Modification number _____

X the latest version is always supplied

Supplementary details _____

L..., LED, V (for descriptions, see Point 2.1)

3. FILTER CALCULATION / SIZING

The total pressure drop of a filter at a certain flow rate Q is the sum of the housing Δp and the element Δp and is calculated as follows:

$$\Delta p_{\text{total}} = \Delta p_{\text{housing}} + \Delta p_{\text{element}}$$

$$\Delta p_{\text{housing}} = (\text{see Point 3.1})$$

$$\Delta p_{\text{element}} = Q \cdot \frac{SK^*}{1000} \cdot \frac{\text{viscosity}}{30}$$

(*see point 3.2)

For ease of calculation, our Filter Sizing Program is available on request free of charge.

NEW: Sizing online at www.hydac.com

3.1 Δp -Q HOUSING CURVES BASED ON ISO 3968

The housing curves apply to mineral oil with a density of 0.86 kg/dm³ and a kinematic viscosity of 30 mm²/s. In this case, the differential pressure changes proportionally to the density.

DFM 160/240/280

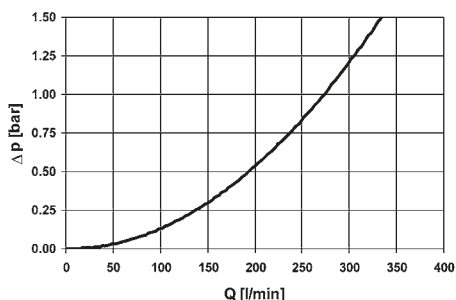

3.2 GRADIENT COEFFICIENTS (SK) FOR FILTER ELEMENTS

The gradient coefficients in mbar/(l/min) apply to mineral oils with a kinematic viscosity of 30 mm²/s. The pressure drop changes proportionally to the change in viscosity.

DFM	BH4HC			
	3 μm	5 μm	10 μm	20 μm
160	16.8	10.4	5.9	4.4
240	10.6	6.8	3.9	2.9
280	5.7	3.4	1.8	1.6

BH4HC: DFM 160

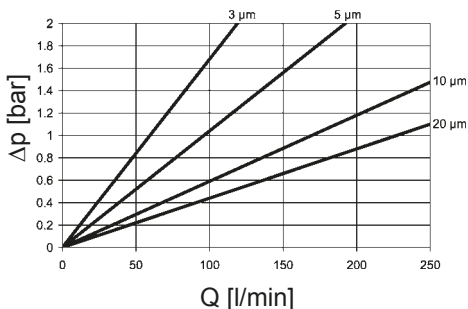

BH4HC: DFM 280

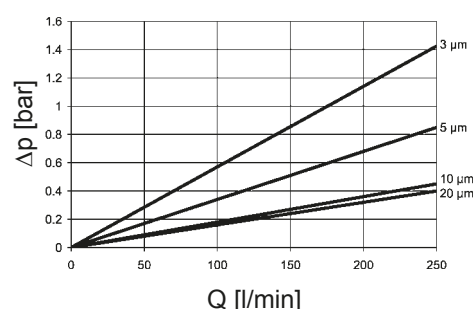

BH4HC: DFM 240

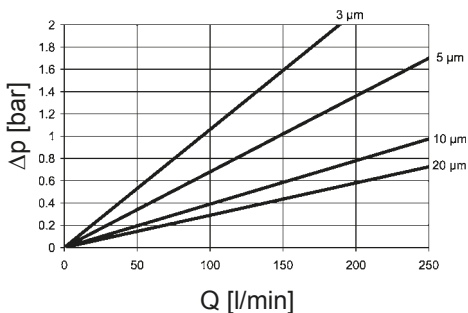

4. DIMENSIONS

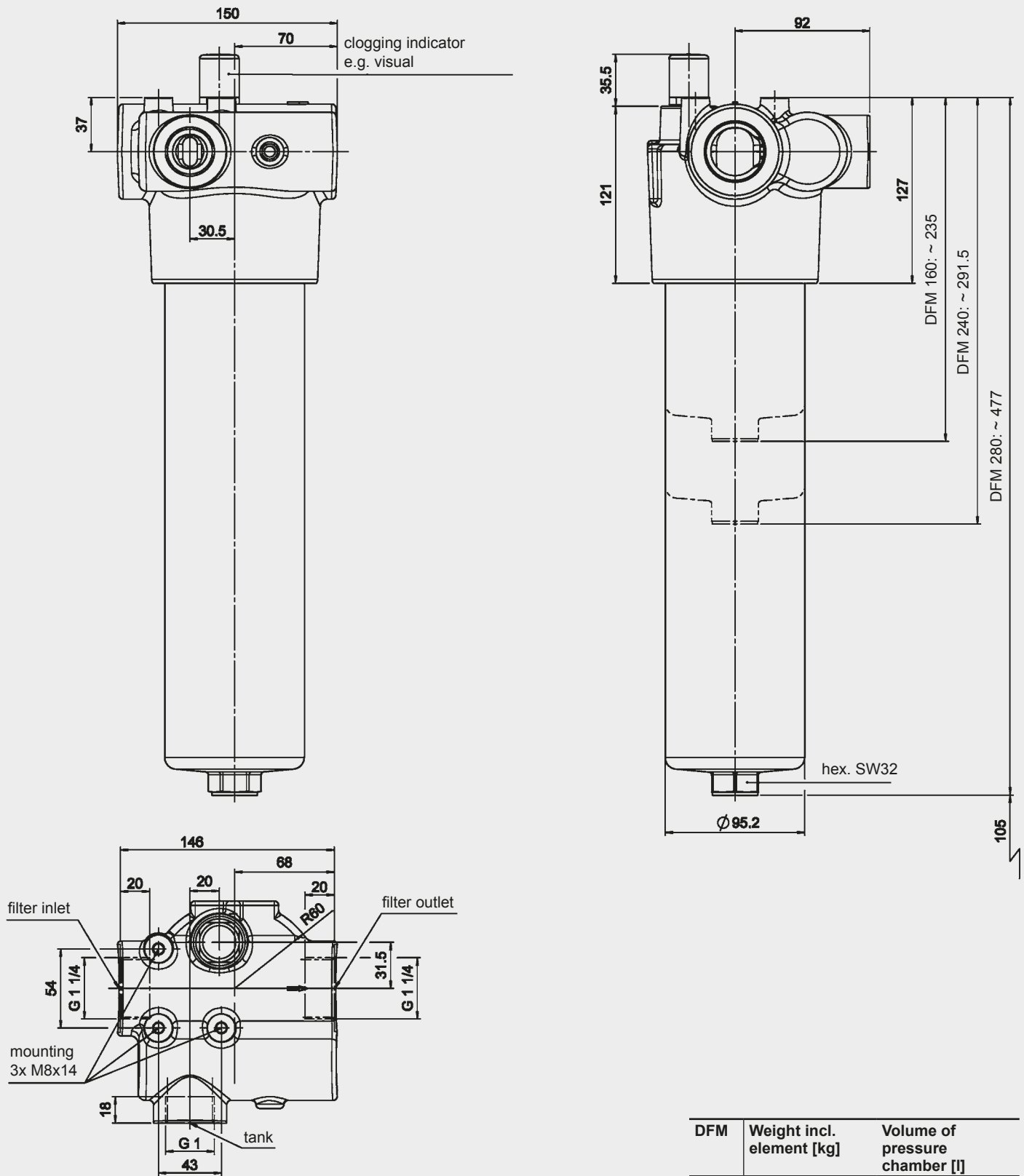

DFM	Weight incl. element [kg]	Volume of pressure chamber [l]
160	11.0	0.6
240	12.5	0.8
280	17.1	1.45

NOTE

The information in this brochure relates to the operating conditions and applications described. For applications or operating conditions not described, please contact the relevant technical department. Subject to technical modifications.

HYDAC Filtrertechnik GmbH
 Industriegebiet
D-66280 Sulzbach/Saar
 Tel.: 0 68 97 / 509-01
 Fax: 0 68 97 / 509-300
 Internet: www.hydac.com
 E-Mail: filter@hydac.com